



E-BOOST ON

TRIPLE-R 1000 – E-BOOST MODE



E-BOOST OFF

TRIPLE-R 1000 – E-MARK COMPLIANT MODE

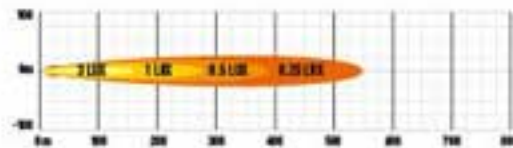

TRIPLE-R

POSITION LIGHT CONNECTOR INSTRUCTIONS

BILBRÖDERNA

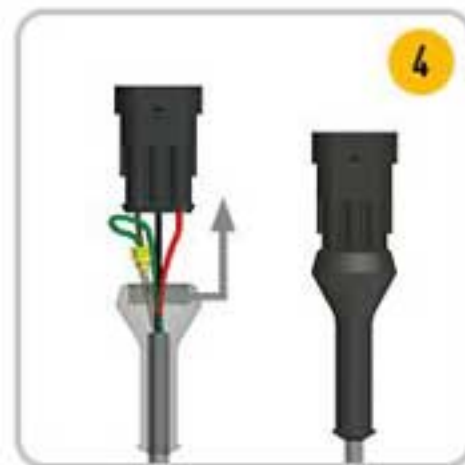

PRODIERNA



BILBRÖDERNA



BILBRÓDKVIA



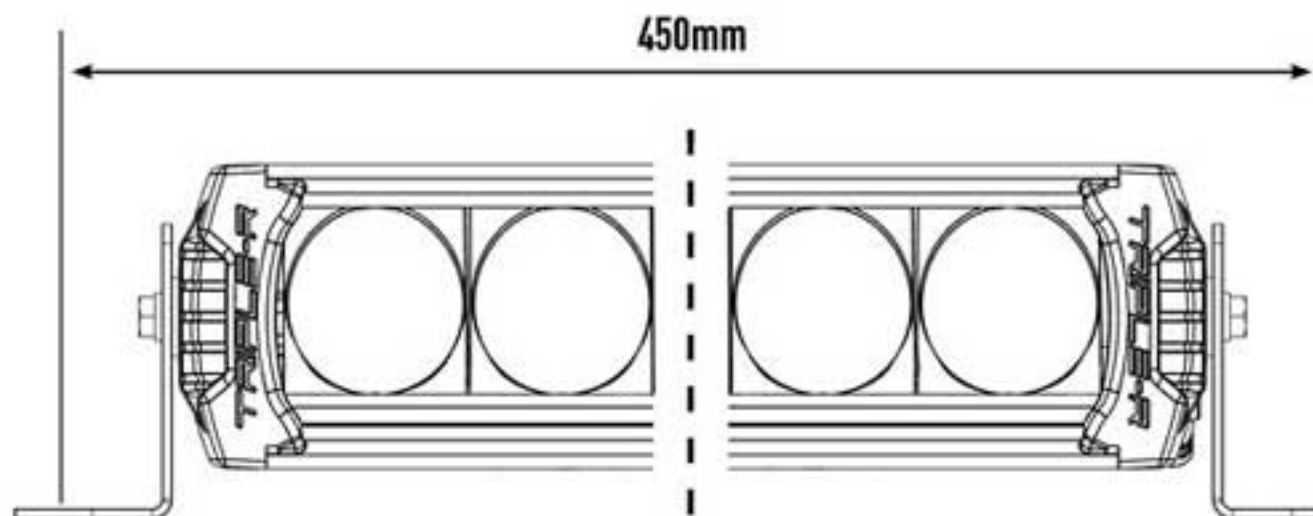
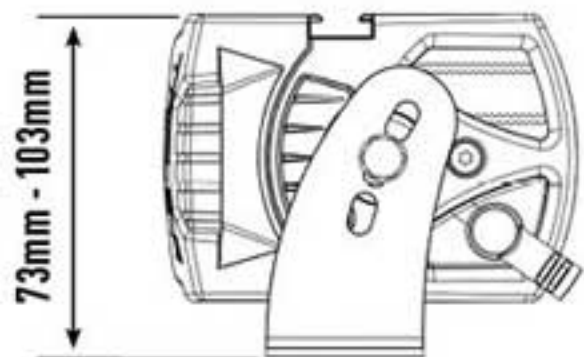
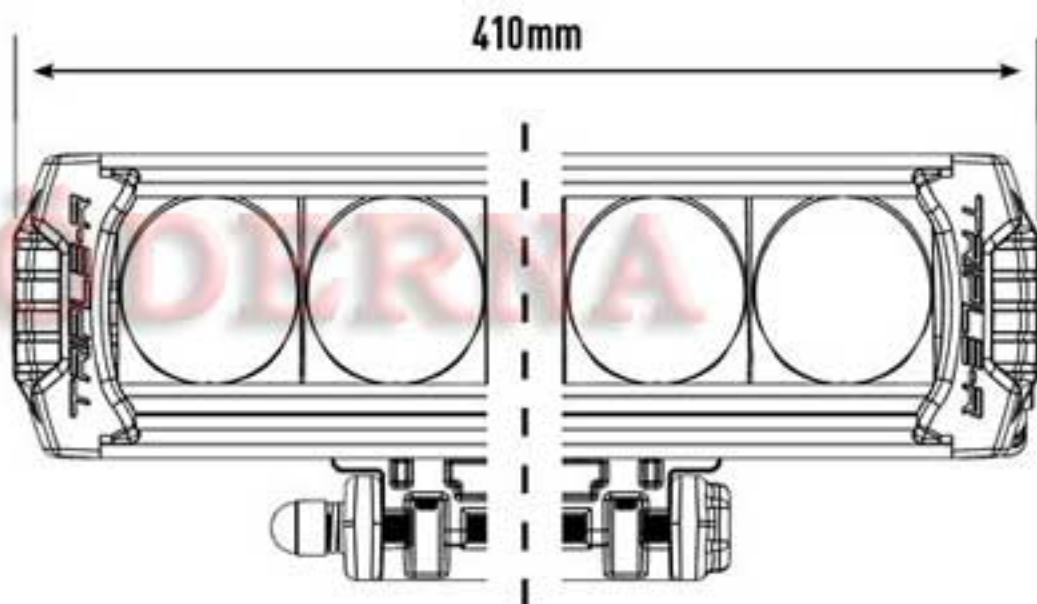
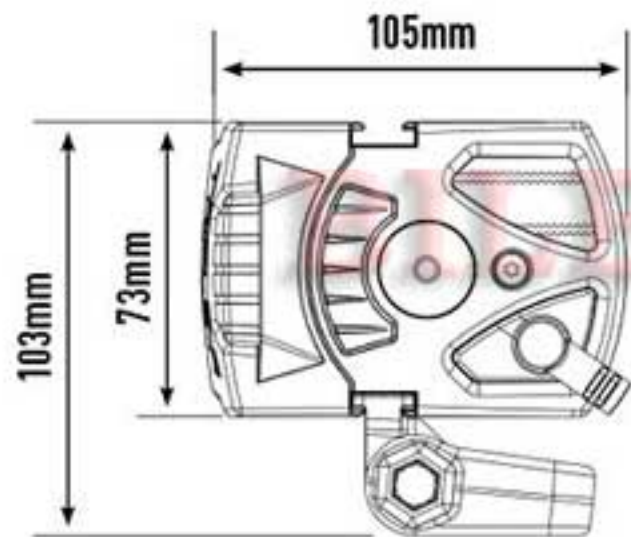

TRIPLE-R 1000 (GEN 2)

GENERATED FROM BSI LAMP PHOTOMETRIC TEST DATA: ON ROAD MEASUREMENT DATA

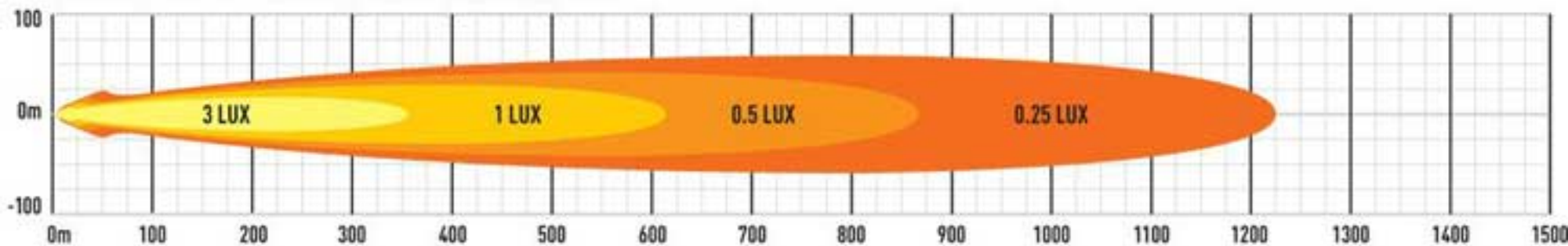

TRIPLE-R 1000 (GEN 2) – E-MARK COMPLIANT MODE

GENERATED FROM BSI LAMP PHOTOMETRIC TEST DATA: ON ROAD MEASUREMENT DATA

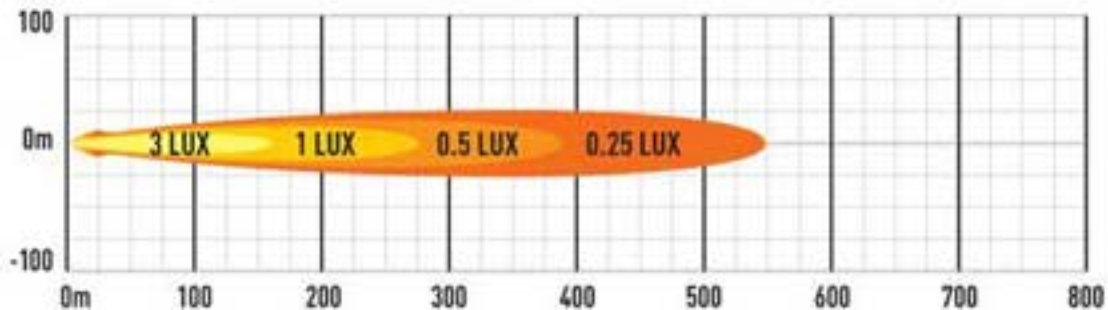



200m
100m



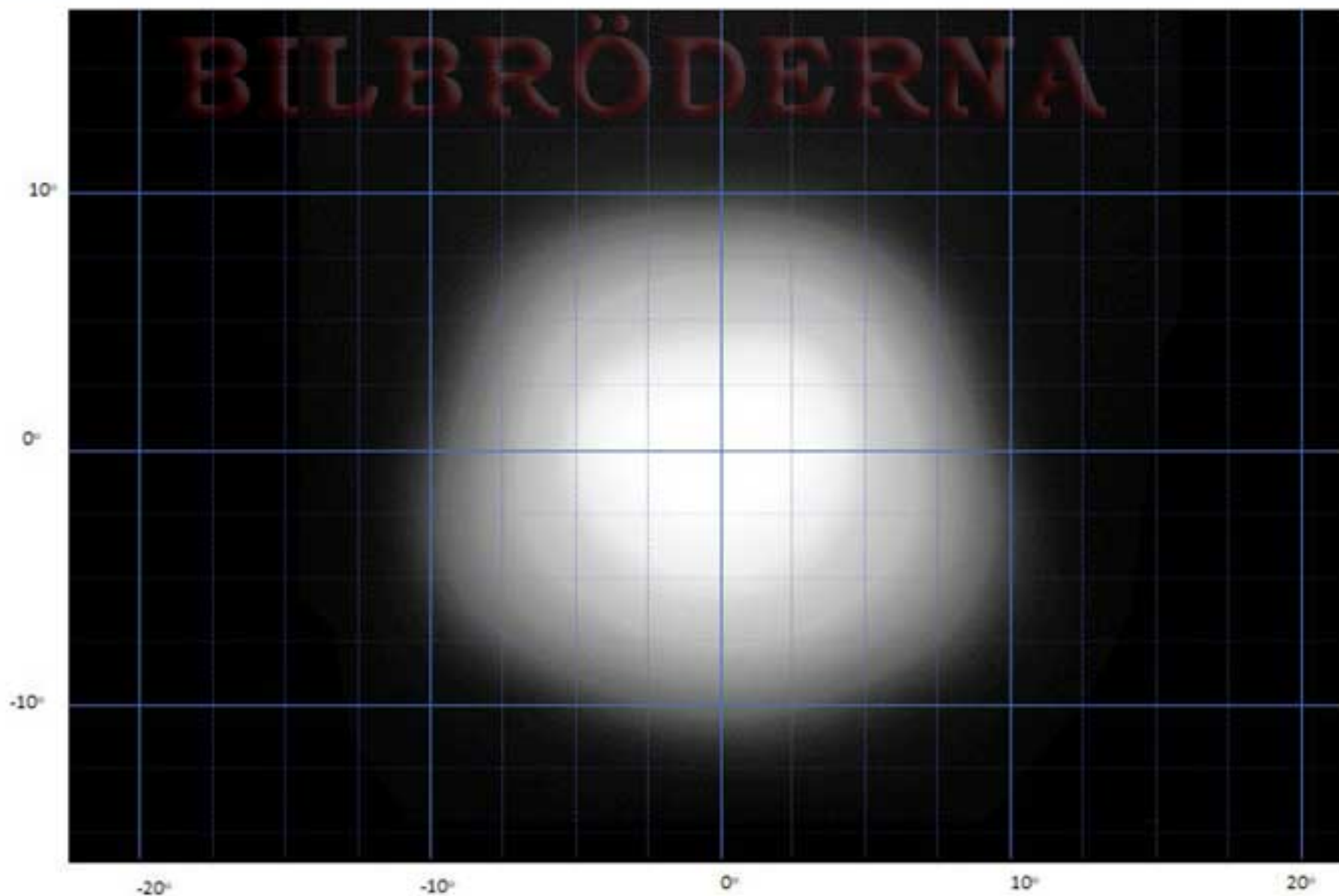

TRIPLER

CORROSION RESISTANCE

enhanced by E-Coat pre-treatment

THERMAL CONDUCTIVITY

maximised through CAE optimised heatsink constructed from anodised aluminium

UNBREAKABLE POLYCARBONATE LENS

with lifetime guarantee

E-BOOST TECHNOLOGY

enables dual output functionality to also achieve ECE approvals.

VACUUM-METALLISED OPTICS

deliver unparalleled reflectivity for maximised light output

OPTIONAL POSITION LIGHT FUNCTION

included across Standard products. White (Reg 7 approved) and Amber colours.

HARDCOAT LACQUER

protects against scratches or deterioration of lens condition

ROAD-LEGAL CERTIFICATION

allows for electrical connection direct to the vehicle's high beam (and side light) signals.

VERSATILE MOUNTING SYSTEM

fully robust and able to position above or below lamp

DYNAMIC DRIVE MODULATION

maintains optimal light output considering the environmental and thermal conditions of the lamp

HIGH INTENSITY 'PREMIUM BIN' LEDs

maximise illumination levels considering power input.

SIDE BRACKET MOUNTING

facilitated with concealed threaded point

