

# LAZER

HIGH PERFORMANCE LIGHTING

## TRIPLE-R 1250 SMARTVIEW (E-BOOST MODE)

RAW LUMENS: 12,170 / 1 LUX @ 732m / E-MARK REF: N/A



100m 200m 300m



1m

5  
YEAR  
WARRANTY

IP67  
WATERPROOF



# LAZER

HIGH PERFORMANCE LIGHTING

## TRIPLE-R 1250 SMARTVIEW (ECE COMPLIANT MODE)

RAW LUMENS: 8,550 / 1 LUX @ 465m / E-MARK REF: 45



1m





# BILBRÖDerna



# BILBRÖDERNA



DASHBOARD CONTROLLER - SOLD SEPERATELY



BILBO...ERNA



BUY FROM RÖDERMANN





# BILBRÖDERNA

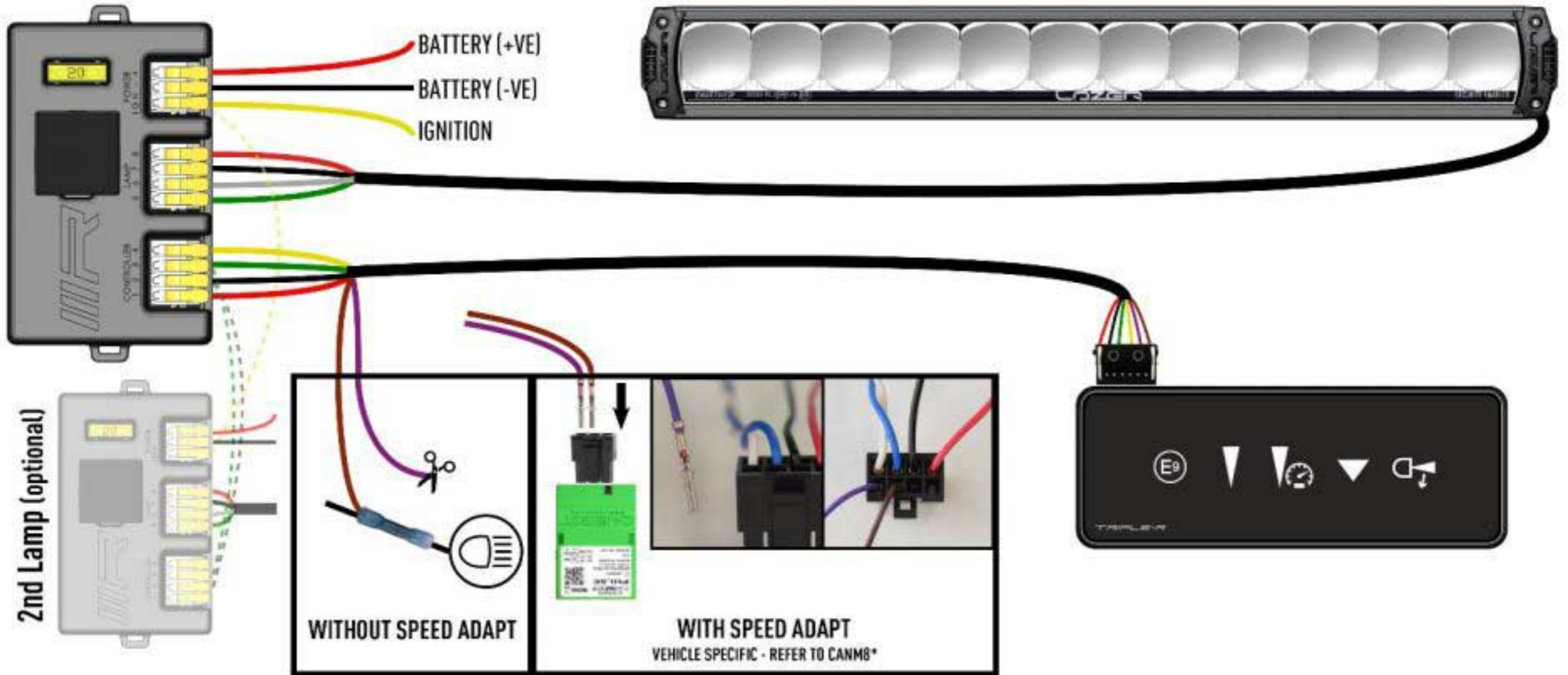

# BILBRÖDERNA

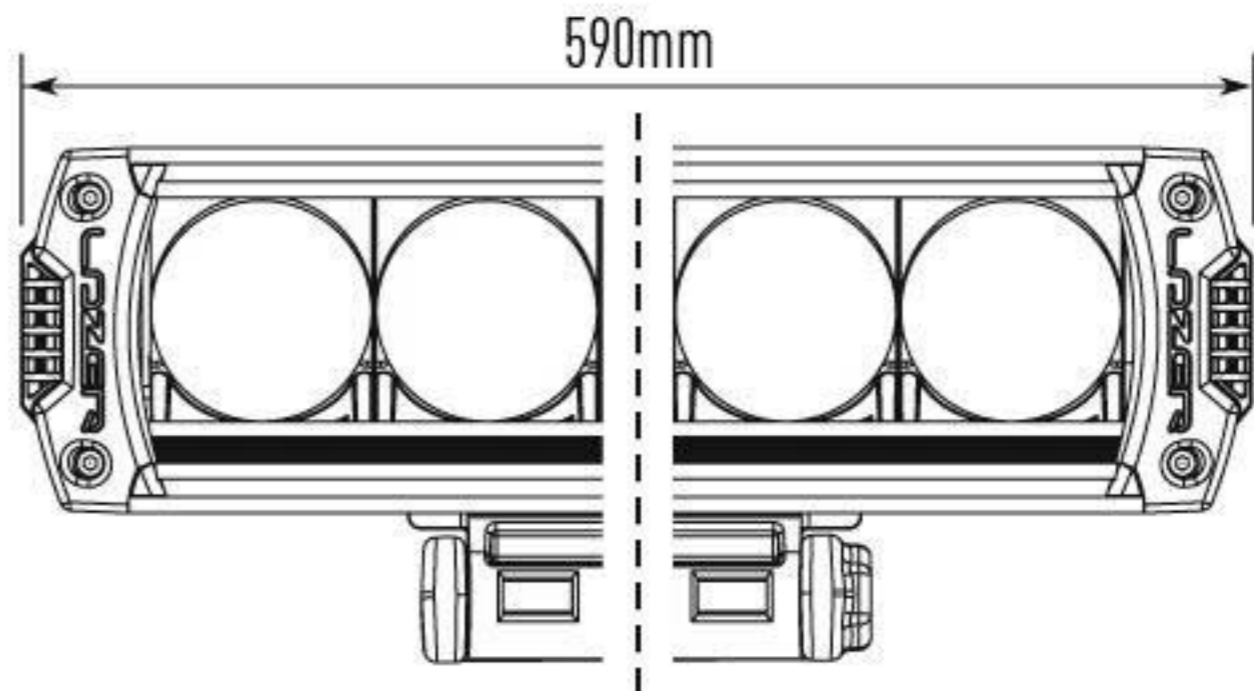
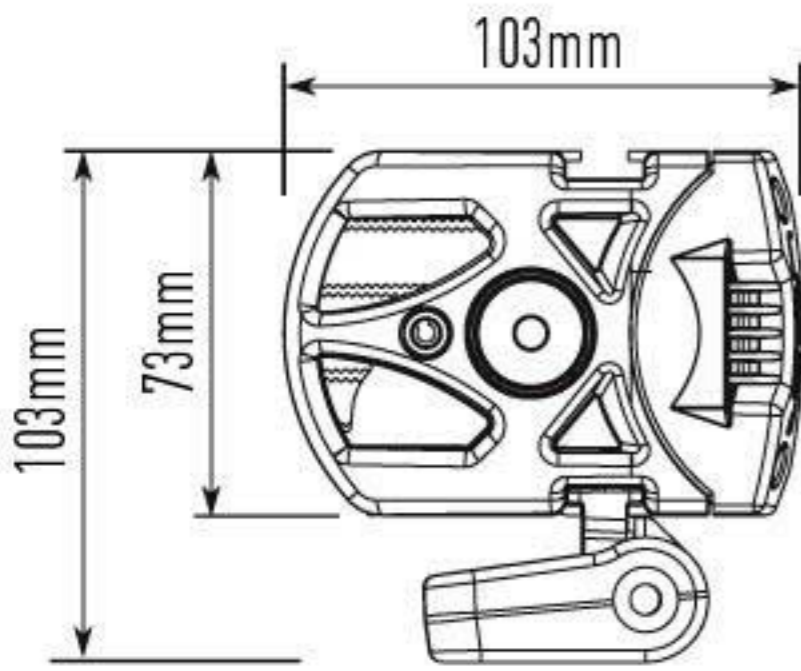
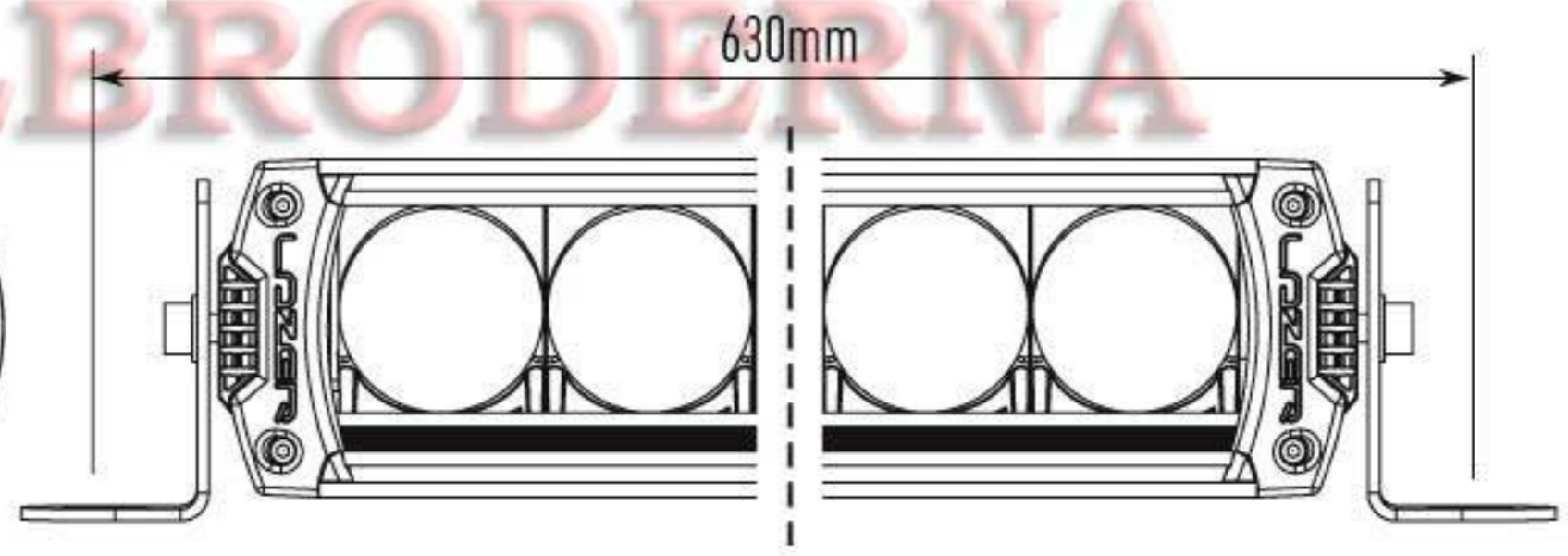
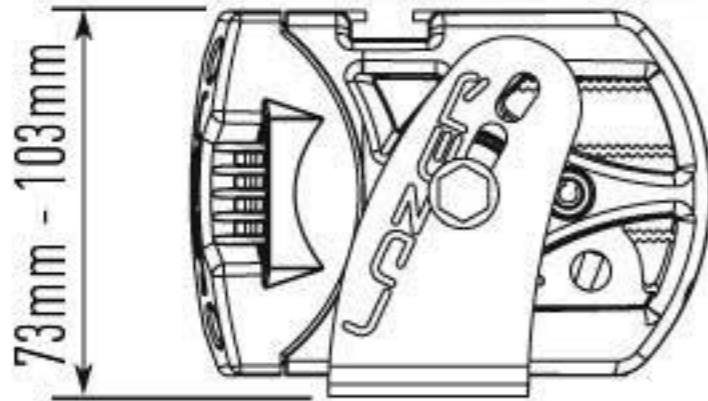



# BILBRÖDERNA

## TRIPLE-R 1250 SMARTVIEW – BOOST FUNCTION ENGAGED\*

GENERATED FROM BSI LAMP PHOTOMETRIC TEST DATA: ON ROAD MEASUREMENT DATA

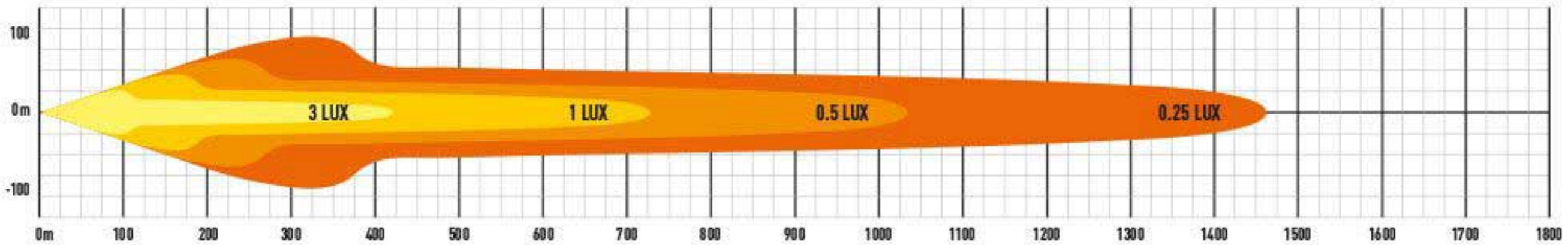

\*BOOST FUNCTION IS ENGAGED WHEN SELECTED VIA THE DASHBOARD CONTROLLER.

## TRIPLE-R 1250 SMARTVIEW – E-MARK COMPLIANT MODE

GENERATED FROM BSI LAMP PHOTOMETRIC TEST DATA: ON ROAD MEASUREMENT DATA

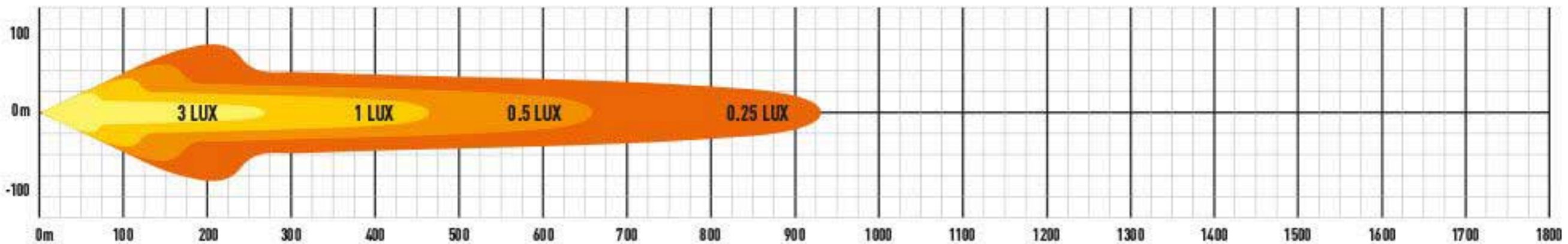







# BILBRÖDERNA

